

# REGULATOR FOR MANIFOLDER

MS-140 / MS-140L / MS-140H

VALVE & EQUIPMENT DIVISION  
VALVE & INSTRUMENTS

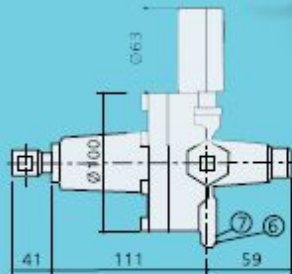
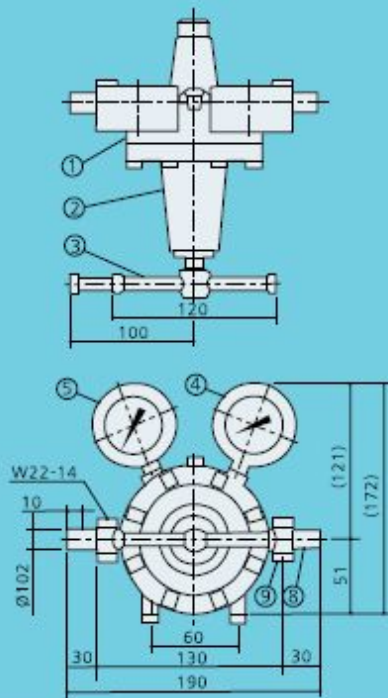

## MATERIAL

NO.	PART NAME
1	BODY
2	COVER
3	HANDLE
4	HP GAUGE
5	LP GAUGE
6	MOUNT BOLT
7	MOUNT WASHER
8	NUT
9	TAIL PIECE

## SPECIFICATION

- Strong Point of SG Regulator
- High Quality
- Reasonable Price
- Perfect Service
- Design complied International Standard
- Wide Range of item related

### Application

Supplying of Small and Medium Sized Gas like Hospital,  
Shipyard, Steel Mill (O<sub>2</sub>, N<sub>2</sub>, Ar, H<sub>2</sub>, He, Co<sub>2</sub>)

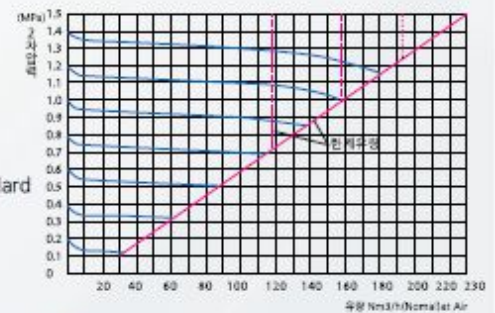

## DIMENSION

unit : mm

SIZE	DIMENSION		INLET	OUTLET	FLOW RATE (Nm³/HR)	FLUID	WEIGHT
	HIGH	LOW					
MS-140	0-25	0-2.5	16.5	1.5	155	Air	3.5
MS-140H	0-35	0-2.5	22	1.5	280	H <sub>2</sub>	3.5
MS-140L	0-5	0-1.5	3.0	1.0	150	Air	3.5

## REGULATOR FOR MANIFOLDER AND PIPING

- Supplying Mass Flow Gas(O<sub>2</sub>, Nitrogen, Argon, H<sub>2</sub>, Helium, CO<sub>2</sub>) stable as Pressure Regulator for Manifold high pressured filled
- Perfect Degreasing by Ultrasonic Oxygen Cleaning complied international standard to use Mass Gas freely
- Pressure Gauge can be handled to confirm Set Pressure complied International Standard.
- If Low Pressure Set is needed, please contact us.