

# LINE SAFETY VALVE

WSL-5111 (LPG)  
WSL-5211 (NH<sub>3</sub>)

VALVE & EQUIPMENT DIVISION  
VALVE & INSTRUMENTS

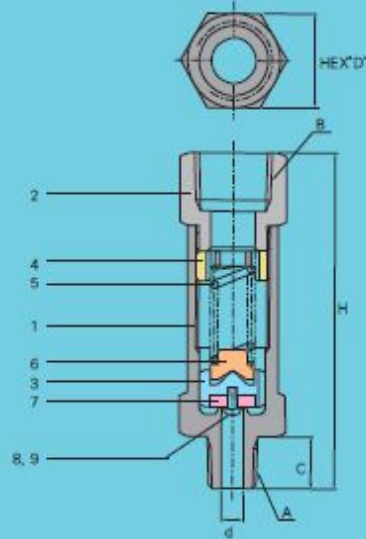

## ■ MATERIAL

NO.	PART NAME	LPG	NH <sub>3</sub>
1	BODY	C3604B	STS 304
2	SOCKET	C3604B	STS 304
3	VALVE DISK	C3604B	STS 304
4	ADJUST SCREW	C3604B	STS 304
5	SPRING	HSW	HSW
6	SPRING DISK	C3604B	STS 304
7	VALVE SEAT	N.B.R	PTFE
8	WASHER	STS 304	STS 304
9	SCREW	STS 304	STS 304

## ■ DIMENSION

SIZE	unit : mm						
	H	D	d	C	A	B	LIFT
8A	90	25	6	14	PT1/4	PT1/4	0.86
15A	107	32	10	18	PT1/2	PT1/2	1.43
20A	129	41	14	22	PT3/4	PT3/4	2
25A	147	45	19	25	PT1	PT1	2.72
40A	167	64	24	30	PT1 1/2	PT1 1/2	3.43

### ※참고\_Remark

1. 암모니아용일 경우 일부 재질을 변경함. \_ 1. Material is to be changed in case of NH<sub>3</sub>
2. 다른 가스 용도로 사용할 경우 당사로 연락바람. \_ 2. Please contact us when applying for other gases