

# HIGH PRESSURE SAFETY VALVE

WLS-5317

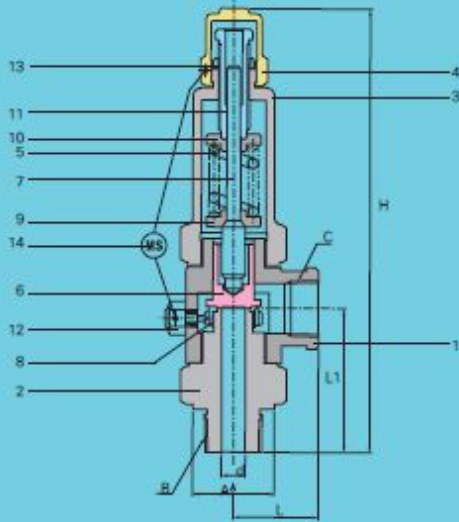

VALVE & EQUIPMENT DIVISION  
VALVE & INSTRUMENTS

## ■ MATERIAL

NO.	PART NAME	MATERIAL	NO.	PART NAME	MATERIAL
1	BODY	STS 304	8	ADJUST RING	STS 304
2	NOZZLE	STS 304	9	LOWER SPRING DISK	STS 304
3	BONNET	STS 304	10	UPPER SPRING DISK	STS 304
4	CAP	STS 304	11	ADJUST SCREW	STS 304
5	SPRING	STS 304	12	SET BOLT	STS 304
6	VALVE DISK	STS 304	13	SET NUT	STS 304
7	SPINDLE	STS 304	14	SEAL	Pb

## ■ DIMENSION

unit : mm

SIZE	H	L	L1	d	A	B	C
10A	205	35	62	8	30	PT 3/8"	PT 3/8"
15A	214	39	67	10	35	PT 1/2"	PT 1/2"
20A	237	42	78	12	36	PT 3/4"	PT 3/4"
25A	270	50	84	16	42	PT 1"	PT 1"
40A	324	70	100	19	45	PT 1 1/2"	PT 1 1/2"
50A	470	86	125	24	48	PT 2"	PT 2"