

CRYOGENIC REGULATOR

WRCG-1000

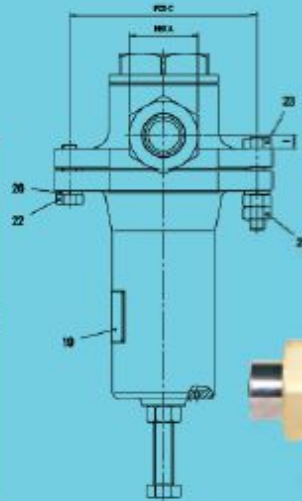
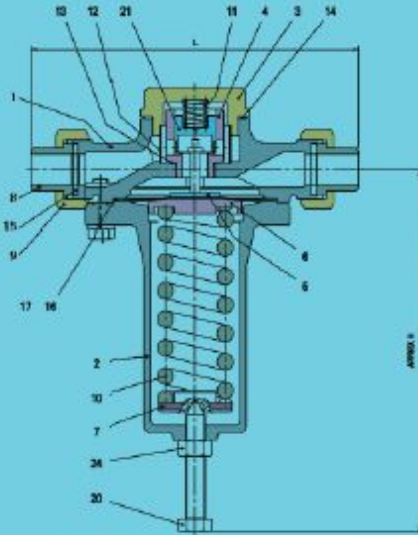

MATERIAL

| NO. | PART NAME | MATERIAL | NO. | PART NAME | MATERIAL |
|-----|-------------------|----------|-----|------------------|----------|
| 1 | BODY | SSC13A | 14 | GASKET | V#7020 |
| 2 | BONNET | SSC13A | 15 | GASKET | V#7020 |
| 3 | BOTTOM COVER | STS304 | 16 | GASKET | PTFE |
| 4 | NOZZLE | C3604 | 17 | DIAPHRAGM | PTFE |
| 5 | STEM | C3604 | 18 | DIAPHRAGM | STS304 |
| 6 | UPPER SPRING DISK | C3604 | 19 | NAME PLATE | STS304 |
| 7 | LOWER SPRING DISK | C3604 | 20 | ADJUST BOLT | C3604 |
| 8 | SLEEVE | STS304 | 21 | VALVE DISK ASS'Y | C3604 |
| 9 | UNION NUT | C3604 | 22 | HEX BOLT | STS304 |
| 10 | SPRING | SAE9254 | 23 | HEX BOLT | STS304 |
| 11 | SPRING | STS304 | 24 | HEX NUT | STS304 |
| 12 | STRAINER | STS304 | 25 | HEX NUT | STS304 |
| 13 | GASKET | PTFE | 26 | SPRING WASHER | STS304 |

DIMENSION

unit: mm

| SIZE | A | C | H | I | L |
|------|----|-----|-----|------|-----|
| 25A | 55 | 151 | 292 | 10.5 | 263 |
| 40A | 70 | 168 | 357 | 17 | 300 |

SPECIFICATION

- Basic setting pressur: 0.7 MPa, 1.4 MPa, 2.4 MPa
- Adjust range : 0.4-1.5 MPa, 1.5-2.5 MPa
- Hydrostatic test pressure : 4.5 MPa
- Pneumatic test pressure : 3.0 MPa
- Fluid : L- O₂, N₂, Ar, LNG
- Design temperature : -196°C ~ +75°C