

LNG FORGED VALVE

MCFG-1000

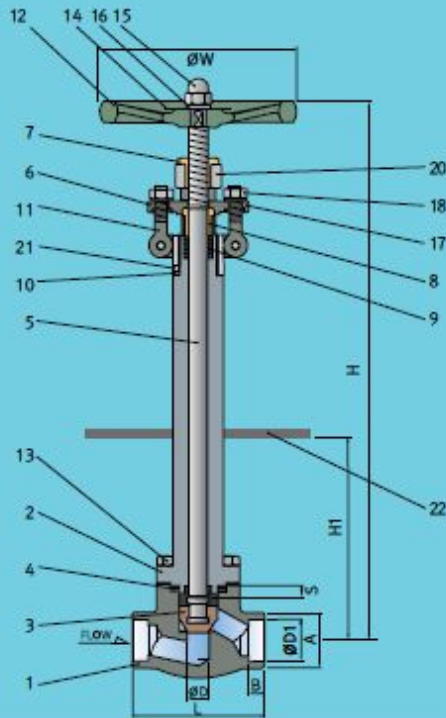

MATERIAL

NO.	PART NAME	MATERIAL	NO.	PART NAME	MATERIAL
1	BODY	A182-F304L	13	HEX BOLT	A320-B8
2	BONNET	A182-F304L	14	NAME PLATE	A1050P
3	VALVE DISK	A276-304L	15	CAP NUT	STS304
4	SPRIAL WOUND	STS304+GRAPHITE	16	SPRING WASHER	STS304
5	SPINDLE	A276-304L	17	SPRING WASHER	STS304
6	GLAND FLANGE	SSC13A	18	NUT	STS304
7	YOKE BUSH	C3604	19	무두볼트	STS304
8	GLAND	C3604	20	무두볼트	STS304
9	PACKING ASS'Y	PTFE	21	무두볼트	STS304
10	YOKE	SSC13A	22	INSULATION PLATE	A240 304
11	YOKE BOLT	STS304	23	TAG NO. PLATE(NO LD)	STS304
12	HANDLE	GCD-S	24	SUS WIRE	STS304

SPECIFICATION

당사의 밸브제작 30여년 노하우가 집약되어 제작되어진 GLOBE V/V는 뛰어난 기밀성, 부드러운 조작성, 화려한 외관을 가진 3위일체 완성형 GLOBE V/V입니다.

- CLASS API 800, 1500
- ANSI 150, 300, 600, 900, 1500
- SIZE 1/2", 1", 1 1/2"

ASTM A105, A182-F5, A182-F9, A182-F11, A182-F22, A182-F304, A182-F316, A182-F304L, A182-F316L, A350-LF2 END CONNECTION SOCKET WELDING, THREADED, BUTT WELDING, FLANGED FEATURE BOLTED BONNET, OUTSIDE SCREW & YOKE, PLUG DISC INTEGRAL SEAT

DIMENSION

SIZE	CLASS	A	B	D	D1	S	L	H1	H	W
1/2"	800	22.5	13	10	16	9.54	111	180.5	448	165
	1500	25.5	13	10	16	18.5	152	206.5	478	165
1"	800	34.5	13	18	25	9.54	111	180.5	448	165
	1500	34.5	13	18	25	18.5	152	206.5	478	165
1-1/2"	800	49	13	30	34	25.7	172	222	584	212
	1500	49	13	30	34	25.7	172	222	584	212

unit : mm